

PHARMAFLO

MULTITUBE FARMACEUTIC SERIE

CSFinoxGroup
FLOW TECHNOLOGY COMPONENTS

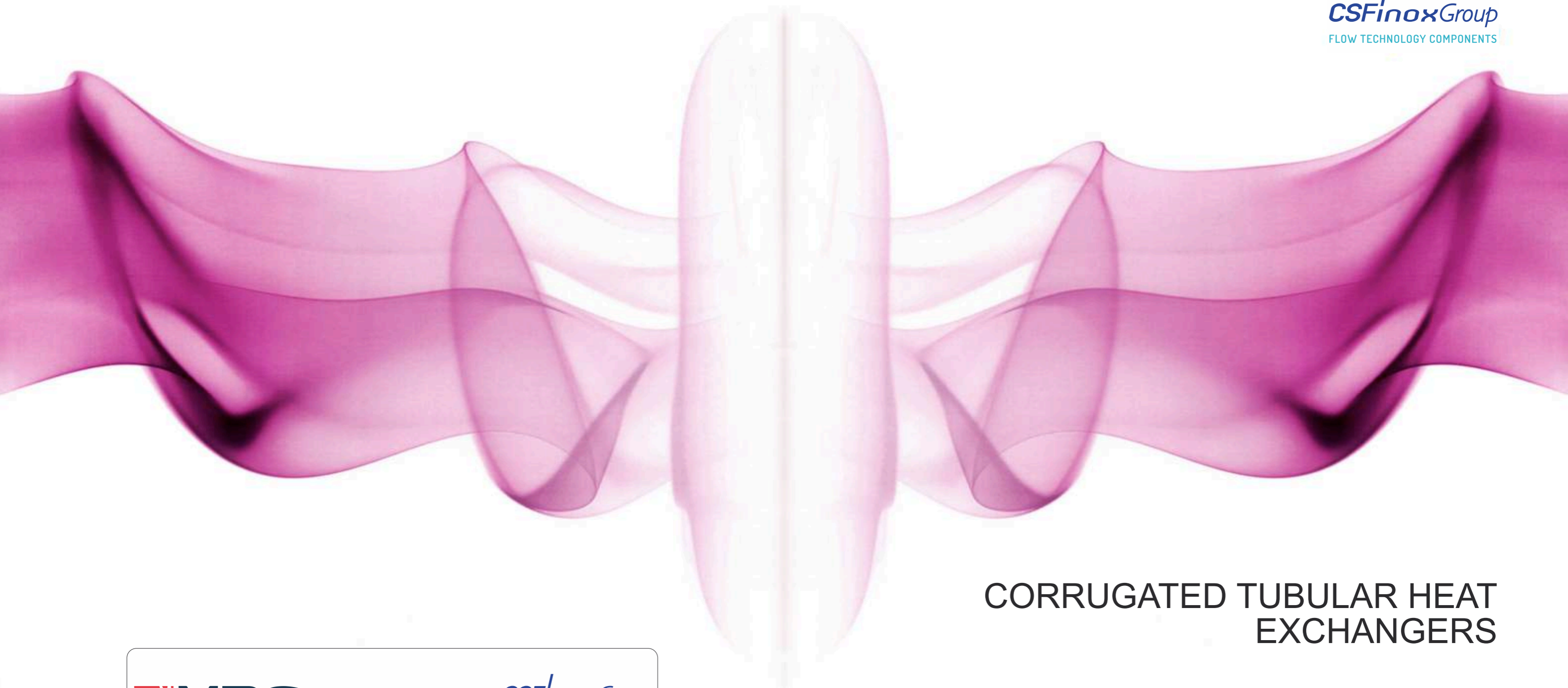

CORRUGATED TUBULAR HEAT EXCHANGERS

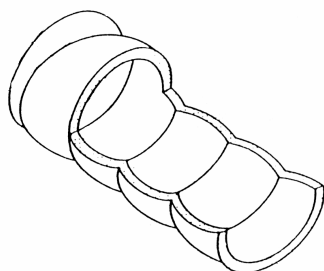

THE CORRUGATION

Corrugation is a particular processing applied on plain tubes to induce dynamic turbulence during the liquids flowing allowing thermal exchange optimization.

With corrugated tubes the thermal exchange efficiency can be enhanced by 40% up to 90% according to the following parameters:

- type of product
- selected profile
- type of application

ADVANTAGES

- reduced exchange surfaces
- reduced contact and standing product time inside the element
- reduced washing time thanks to a higher action produced by turbulence
- vertical or horizontal installation
- working possibilities with high pressures and temperatures
- gaskets-free design so lower maintenance costs
- easy to install and exchanger modularity

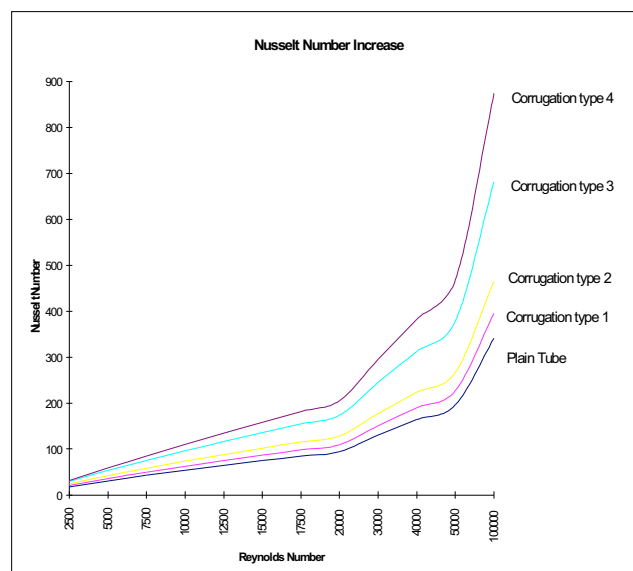

Sanitary pharmaflo multitube serie

PHARMAFLO Heat Exchanger is realized to meet the pharmaceutical industry need/request of high hygienic measures.

PHARMAFLO Heat Exchanger is manufactured by small diameter corrugated tubes inside an external jacket with tube plate on both ends. This solution remove the possibility of any contamination between sterile product and service fluid.

An expansion joint is fitted on external jacket.

The product to be thermally processed flows inside the small diameter tubes while service fluid flows inside the external jacket.

Application range

Particularly suited for thermal exchange process of pharmaceutical fluids having a low or medium viscosity as for example WFI point of use cooling - WFI heating - condensation.

Standard materials

Stainless steel AISI 316 L seamless tubes
(Other kind of materials are available on request)

Finishing

Ra < 0,5 μm product side
(Other finishing on request)

Standard pressure project

10 bar
(Higher pressures are available depending an utilized connections)

Standard temperature project

184°C

Connections

CLAMP-FLANGE



Every exchanger is in accordance with 2014/68/UE Directive (PED)

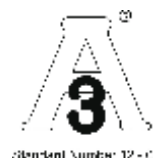

MODEL	SHELL VOLUME [litres]	TUBES VOLUME [litres]	EXCHANGE AREA [m ²]	SHELL SECTION [mm ²]	TUBES SECTION [mm ²]	WEIGHT [kg]
MLP 60 4 18 1 1000	1.39	0.67	0.19	1471.59	804.25	6.1
MLP 60 4 18 1 1500	2.12	1.07	0.30	1471.59	804.25	8.4
MLP 60 4 18 1 2000	2.86	1.48	0.42	1471.59	804.25	10.7
MLP 60 4 18 1 3000	4.33	2.28	0.64	1471.59	804.25	15.2
MLP 60 4 18 1 6000	8.74	4.69	1.32	1471.59	804.25	28.9

Category calculation for second group's fluids - Gas, melted gas and liquids with a steam tension at maximum temperature > 0.5 bar

Article 4.3
 1st Category
 2nd Category
 3rd Category

MODEL	VOLUME [litres]	PRESSURE [bar] *											
		1	2	3	4	5	6	7	8	9	10	11	12
MLP 60 4 18 1 1000	Shell / Tubes												
MLP 60 4 18 1 1500	Shell / Tubes												
MLP 60 4 18 1 2000	Shell / Tubes												
MLP 60 4 18 1 3000	Shell / Tubes											11.5	
MLP 60 4 18 1 6000	Shell / Tubes					5.7						10.6	

* for higher pressure contact MBS

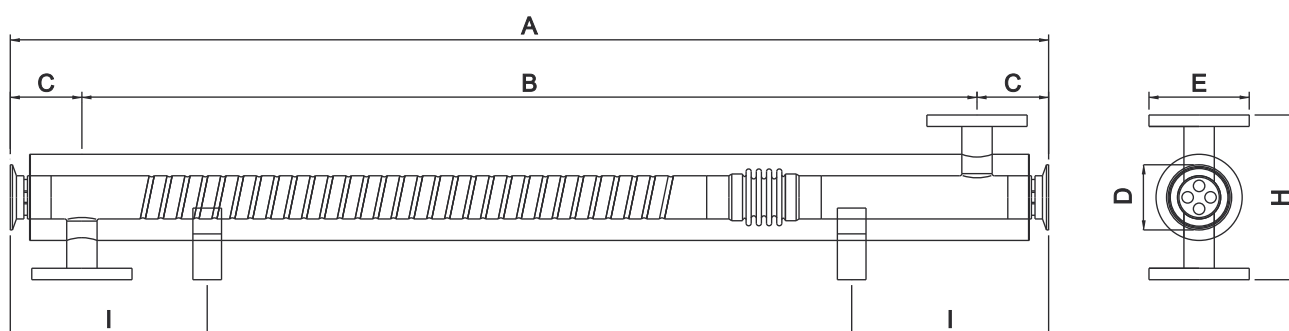

MODEL	DIMENSIONS [mm]						
	A	B	C	D	E	H	I
MLP 60 4 18 1 1000	950	700	125	DIN 32676 DN 65 ASME BPE CLAMP 2" 1/2 more connections on demand	EN 1092-1 DN 32 PN.16 more connections on demand	230	275
MLP 60 4 18 1 1500	1450	1200					
MLP 60 4 18 1 2000	1950	1700					
MLP 60 4 18 1 3000	2950	2700					
MLP 60 4 18 1 6000	5950	5700					

Not binding technical datas; may be modified by the Manufactures without advise

MODEL	SHELL VOLUME [litres]	TUBES VOLUME [litres]	EXCHANGE AREA [m ²]	SHELL SECTION [mm ²]	TUBES SECTION [mm ²]	WEIGHT [kg]
MLP 60 7 12 1 1000	1.57	0.46	0.22	1697.79	549.78	6.4
MLP 60 7 12 1 1500	2.42	0.73	0.35	1697.79	549.78	8.7
MLP 60 7 12 1 2000	3.27	1.01	0.48	1697.79	549.78	11.1
MLP 60 7 12 1 3000	4.97	1.56	0.75	1697.79	549.78	15.9
MLP 60 7 12 1 6000	10.06	3.21	1.54	1697.79	549.78	30.2

Category calculation for second group's fluids - Gas, melted gas and liquids with a steam tension at maximum temperature > 0.5 bar

Article 4.3
 1st Category
 2nd Category
 3rd Category

MODEL	VOLUME [litres]	PRESSURE [bar] *											
		1	2	3	4	5	6	7	8	9	10	11	12
MLP 60 7 12 1 1000	Shell / Tubes												
MLP 60 7 12 1 1500	Shell / Tubes												
MLP 60 7 12 1 2000	Shell / Tubes												
MLP 60 7 12 1 3000	Shell / Tubes										10.0		
MLP 60 7 12 1 6000	Shell / Tubes				4.9								

* for higher pressure contact MBS

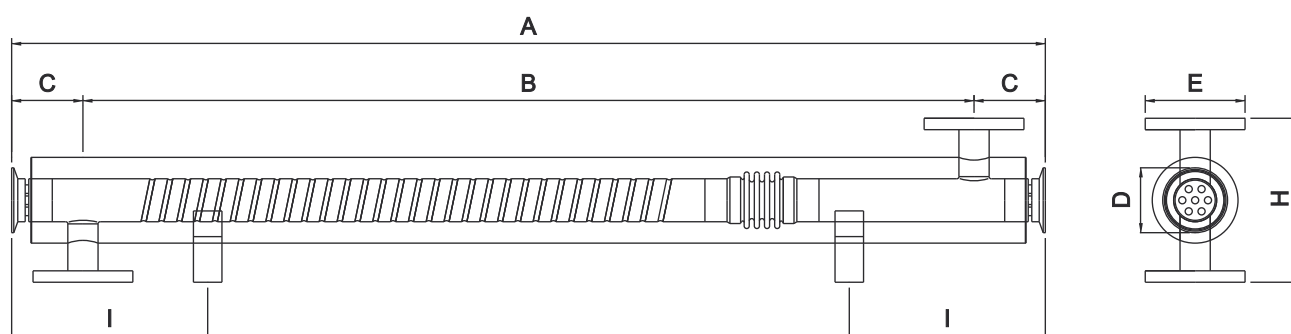

MODEL	DIMENSIONS [mm]						
	A	B	C	D	E	H	I
MLP 60 7 12 1 1000	950	700	125	DIN 32676 DN 65 ASME BPE CLAMP 2" 1/2 more connections on demand	EN 1092-1 DN 32 PN.16 more connections on demand	230	275
MLP 60 7 12 1 1500	1450	1200					
MLP 60 7 12 1 2000	1950	1700					
MLP 60 7 12 1 3000	2950	2700					
MLP 60 7 12 1 6000	5950	5700					

Not binding technical datas; may be modified by the Manufactures without advise

MODEL	SHELL VOLUME [litres]	TUBES VOLUME [litres]	EXCHANGE AREA [m ²]	SHELL SECTION [mm ²]	TUBES SECTION [mm ²]	WEIGHT [kg]
MLP 76 7 18 1 1000	2.19	1.18	0.33	2301.54	1407.43	9.2
MLP 76 7 18 1 1500	3.34	1.88	0.53	2301.54	1407.43	12.5
MLP 76 7 18 1 2000	4.49	2.58	0.73	2301.54	1407.43	15.8
MLP 76 7 18 1 3000	6.80	3.99	1.12	2301.54	1407.43	22.3
MLP 76 7 18 1 6000	13.70	8.21	2.31	2301.54	1407.43	42

Category calculation for second group's fluids - Gas, melted gas and liquids with a steam tension at maximum temperature > 0.5 bar

Article 4.3
 1st Category
 2nd Category
 3rd Category

MODEL	VOLUME [litres]	PRESSURE [bar] *											
		1	2	3	4	5	6	7	8	9	10	11	12
MLP 76 7 18 1 1000	Shell / Tubes												
MLP 76 7 18 1 1500	Shell / Tubes												
MLP 76 7 18 1 2000	Shell / Tubes										11.1		
MLP 76 7 18 1 3000	Shell / Tubes							7.3					12.5
MLP 76 7 18 1 6000	Shell / Tubes			3.6				6.0					

* for higher pressure contact MBS

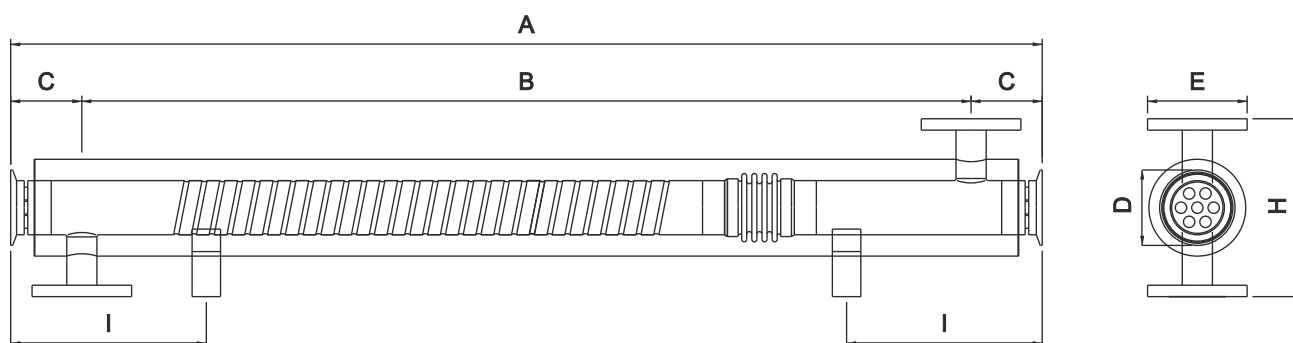

MODEL	DIMENSIONS [mm]						
	A	B	C	D	E	H	I
MLP 76 7 18 1 1000	950	700	125	DIN 32676 DN 80 ASME BPE CLAMP 3"	EN 1092-1 DN 40 PN.16	250	275
MLP 76 7 18 1 1500	1450	1200					
MLP 76 7 18 1 2000	1950	1700					
MLP 76 7 18 1 3000	2950	2700					
MLP 76 7 18 1 6000	5950	5700					

Not binding technical datas; may be modified by the Manufactures without advise

MODEL	SHELL VOLUME [litres]	TUBES VOLUME [litres]	EXCHANGE AREA [m ²]	SHELL SECTION [mm ²]	TUBES SECTION [mm ²]	WEIGHT [kg]
MLP 76 10 12 1 1000	2.74	0.66	0.32	2951.85	785.40	9.0
MLP 76 10 12 1 1500	4.21	1.05	0.50	2951.85	785.40	12.2
MLP 76 10 12 1 2000	5.69	1.44	0.69	2951.85	785.40	15.3
MLP 76 10 12 1 3000	8.64	2.23	1.07	2951.85	785.40	21.7
MLP 76 10 12 1 6000	17.50	4.58	2.20	2951.85	785.40	40.7

Category calculation for second group's fluids - Gas, melted gas and liquids with a steam tension at maximum temperature > 0.5 bar

Article 4.3
 1st Category
 2nd Category
 3rd Category

MODEL	VOLUME [litres]	PRESSURE [bar] *											
		1	2	3	4	5	6	7	8	9	10	11	12
MLP 76 10 12 1 1000	Shell / Tubes												
MLP 76 10 12 1 1500	Shell / Tubes											11.8	
MLP 76 10 12 1 2000	Shell / Tubes							8.7					
MLP 76 10 12 1 3000	Shell / Tubes					5.7							
MLP 76 10 12 1 6000	Shell / Tubes		2.8								10.9	11.4	

* for higher pressure contact MBS

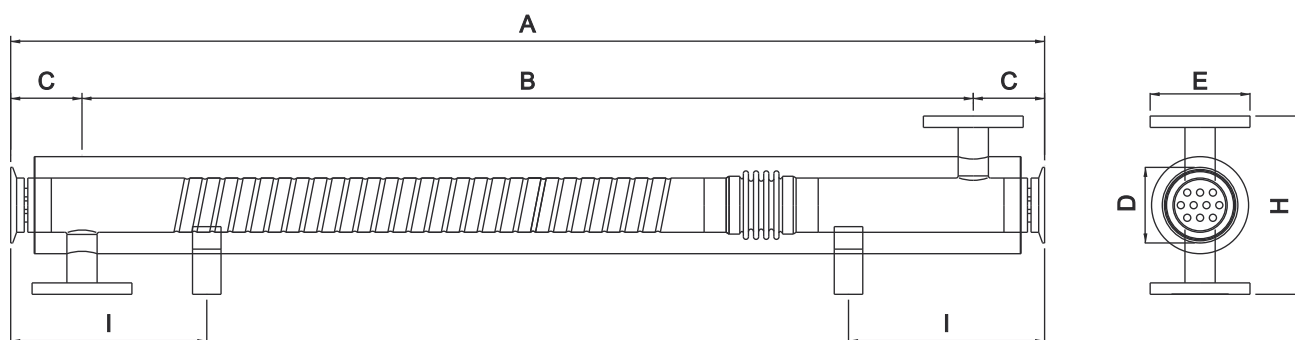

MODEL	DIMENSIONS [mm]						
	A	B	C	D	E	H	I
MLP 76 10 12 1 1000	950	700	125	DIN 32676 DN 80 ASME BPE CLAMP 3"	EN 1092-1 DN 40 PN.16	250	275
MLP 76 10 12 1 1500	1450	1200					
MLP 76 10 12 1 2000	1950	1700					
MLP 76 10 12 1 3000	2950	2700					
MLP 76 10 12 1 6000	5950	5700					

Not binding technical datas; may be modified by the Manufactures without advise

MODEL	SHELL VOLUME [litres]	TUBES VOLUME [litres]	EXCHANGE AREA [m ²]	SHELL SECTION [mm ²]	TUBES SECTION [mm ²]	WEIGHT [kg]
MLP 88 10 18 1 1000	3.10	1.68	0.47	3116.47	2010.62	12.1
MLP 88 10 18 1 1500	4.66	2.69	0.76	3116.47	2010.62	16.3
MLP 88 10 18 1 2000	6.21	3.69	1.04	3116.47	2010.62	20.5
MLP 88 10 18 1 3000	9.33	5.70	1.60	3116.47	2010.62	29.0
MLP 88 10 18 1 6000	18.68	11.73	3.30	3116.47	2010.62	54.3

Category calculation for second group's fluids - Gas, melted gas and liquids with a steam tension at maximum temperature > 0.5 bar

Article 4.3
 1st Category
 2nd Category
 3rd Category

MODEL	VOLUME [litres]	PRESSURE [bar] *											
		1	2	3	4	5	6	7	8	9	10	11	12
MLP 88 10 18 1 1000	Shell / Tubes												
MLP 88 10 18 1 1500	Shell / Tubes										10.7		
MLP 88 10 18 1 2000	Shell / Tubes								8.0				
MLP 88 10 18 1 3000	Shell / Tubes					5.3			8.7				
MLP 88 10 18 1 6000	Shell / Tubes		2.6			4.2					10.7		

* for higher pressure contact MBS

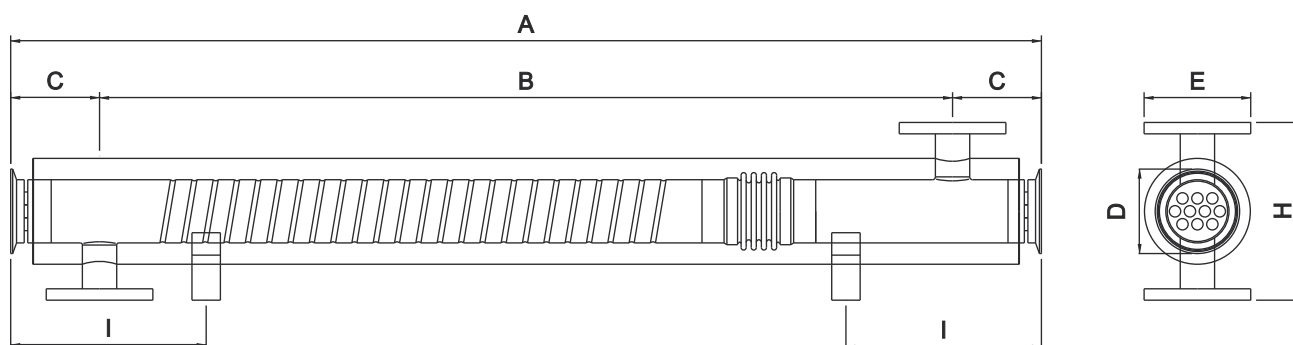

MODEL	DIMENSIONS [mm]						
	A	B	C	D	E	H	I
MLP 88 10 18 1 1000	950	700	125	DIN 32676 DN 100 ASME BPE CLAMP 4"	EN 1092-1 DN 50 PN.16	280	275
MLP 88 10 18 1 1500	1450	1200					
MLP 88 10 18 1 2000	1950	1700					
MLP 88 10 18 1 3000	2950	2700					
MLP 88 10 18 1 6000	5950	5700					

Not binding technical datas; may be modified by the Manufactures without advise

MODEL	SHELL VOLUME [litres]	TUBES VOLUME [litres]	EXCHANGE AREA [m ²]	SHELL SECTION [mm ²]	TUBES SECTION [mm ²]	WEIGHT [kg]
MLP 88 19 12 1 1000	3.43	1.25	0.60	3512.31	1492.26	13.0
MLP 88 19 12 1 1500	5.19	1.99	0.96	3512.31	1492.26	17.7
MLP 88 19 12 1 2000	6.94	2.74	1.32	3512.31	1492.26	22.4
MLP 88 19 12 1 3000	10.45	4.23	2.03	3512.31	1492.26	31.8
MLP 88 19 12 1 6000	20.99	8.71	4.18	3512.31	1492.26	60.0

Category calculation for second group's fluids - Gas, melted gas and liquids with a steam tension at maximum temperature > 0.5 bar

Article 4.3
 1st Category
 2nd Category
 3rd Category

MODEL	VOLUME [litres]	PRESSURE [bar] *											
		1	2	3	4	5	6	7	8	9	10	11	12
MLP 88 19 12 1 1000	Shell / Tubes												
MLP 88 19 12 1 1500	Shell / Tubes									9.6			
MLP 88 19 12 1 2000	Shell / Tubes							7.2					
MLP 88 19 12 1 3000	Shell / Tubes				4.7							11.8	
MLP 88 19 12 1 6000	Shell / Tubes		2.3				5.7				9.5		

* for higher pressure contact MBS

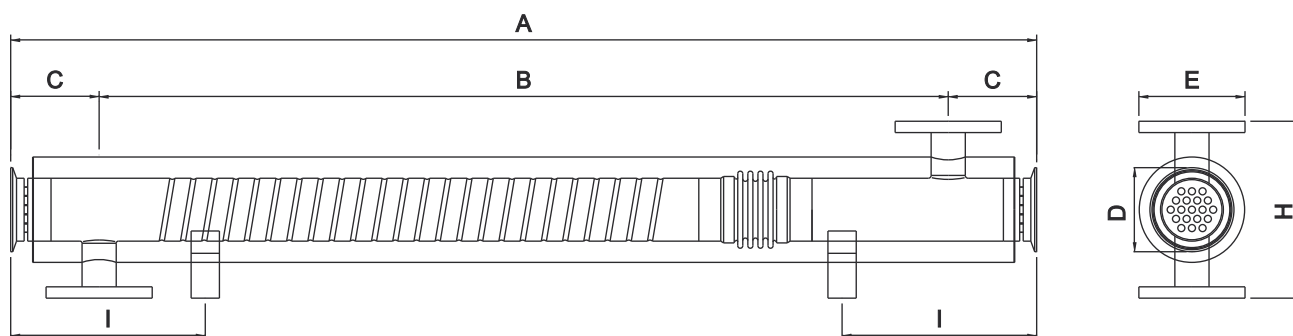

MODEL	DIMENSIONS [mm]						
	A	B	C	D	E	H	I
MLP 88 19 12 1 1000	950	700	125	DIN 32676 DN 100 ASME BPE CLAMP 4"	EN 1092-1 DN 50 PN.16	280	275
MLP 88 19 12 1 1500	1450	1200					
MLP 88 19 12 1 2000	1950	1700					
MLP 88 19 12 1 3000	2950	2700					
MLP 88 19 12 1 6000	5950	5700					

Not binding technical datas; may be modified by the Manufactures without advise

MODEL	SHELL VOLUME [litres]	TUBES VOLUME [litres]	EXCHANGE AREA [m ²]	SHELL SECTION [mm ²]	TUBES SECTION [mm ²]	WEIGHT [kg]
MLP 114 19 18 1 1000	4.94	3.15	0.89	4720.31	3820.18	19.5
MLP 114 19 18 1 1500	7.30	5.06	1.42	4720.31	3820.18	26.2
MLP 114 19 18 1 2000	9.66	6.97	1.96	4720.31	3820.18	33.0
MLP 114 19 18 1 3000	14.38	10.79	3.03	4720.31	3820.18	46.4
MLP 114 19 18 1 6000	28.54	22.25	6.26	4720.31	3820.18	86.8

Category calculation for second group's fluids - Gas, melted gas and liquids with a steam tension at maximum temperature > 0.5 bar

Article 4.3
 1st Category
 2nd Category
 3rd Category

MODEL	VOLUME [litres]	PRESSURE [bar] *											
		1	2	3	4	5	6	7	8	9	10	11	12
MLP 114 19 18 1 1000	Shell / Tubes										10.1		
MLP 114 19 18 1 1500	Shell / Tubes						6.8				9.8		
MLP 114 19 18 1 2000	Shell / Tubes					5.1		7.1					
MLP 114 19 18 1 3000	Shell / Tubes			3.4	4.6								
MLP 114 19 18 1 6000	Shell / Tubes	1.7	2.2					7.0	8.9				

* for higher pressure contact MBS

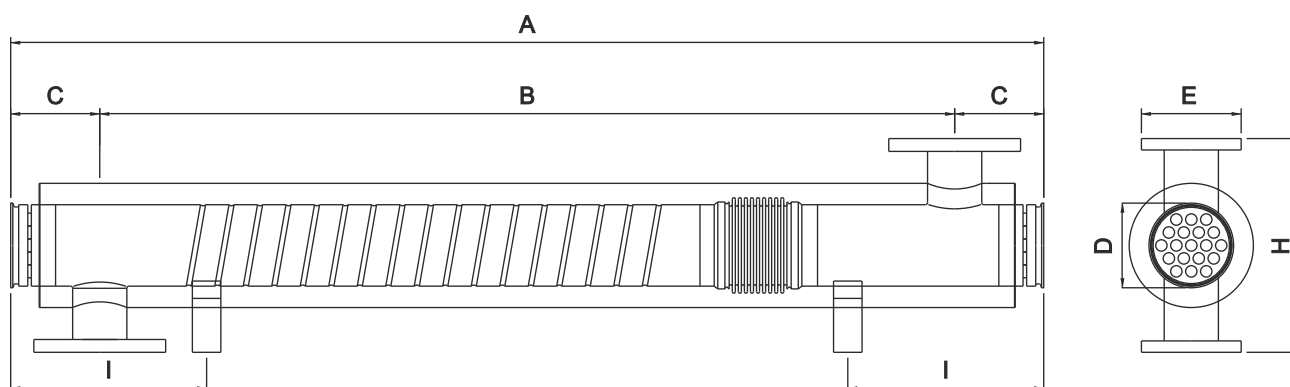

MODEL	DIMENSIONS [mm]						
	A	B	C	D	E	H	I
MLP 114 19 18 1 1000	950	700	125	CLAMP 4"	EN 1092-1 DN 65 PN.16	300	275
MLP 114 19 18 1 1500	1450	1200					
MLP 114 19 18 1 2000	1950	1700					
MLP 114 19 18 1 3000	2950	2700					
MLP 114 19 18 1 6000	5950	5700					

Not binding technical datas; may be modified by the Manufactures without advise

MODEL	SHELL VOLUME [litres]	TUBES VOLUME [litres]	EXCHANGE AREA [m ²]	SHELL SECTION [mm ²]	TUBES SECTION [mm ²]	WEIGHT [kg]
MLP 114 37 12 1 1000	5.48	2.39	1.15	5370.62	2905.97	21.4
MLP 114 37 12 1 1500	8.16	3.85	1.85	5370.62	2905.97	29.2
MLP 114 37 12 1 2000	10.85	5.30	2.54	5370.62	2905.97	36.9
MLP 114 37 12 1 3000	16.22	8.21	3.94	5370.62	2905.97	52.5
MLP 114 37 12 1 6000	32.33	16.92	8.12	5370.62	2905.97	99.1

Category calculation for second group's fluids - Gas, melted gas and liquids with a steam tension at maximum temperature > 0.5 bar

Article 4.3
 1st Category
 2nd Category
 3rd Category

MODEL	VOLUME [litres]	PRESSURE [bar] *											
		1	2	3	4	5	6	7	8	9	10	11	12
MLP 114 37 12 1 1000	Shell / Tubes									9.1			
MLP 114 37 12 1 1500	Shell / Tubes						6.1						12.9
MLP 114 37 12 1 2000	Shell / Tubes				4.6						9.4		
MLP 114 37 12 1 3000	Shell / Tubes			3.0				6.0					12.3
MLP 114 37 12 1 6000	Shell / Tubes	1.5		2.9				6.1					11.8

* for higher pressure contact MBS

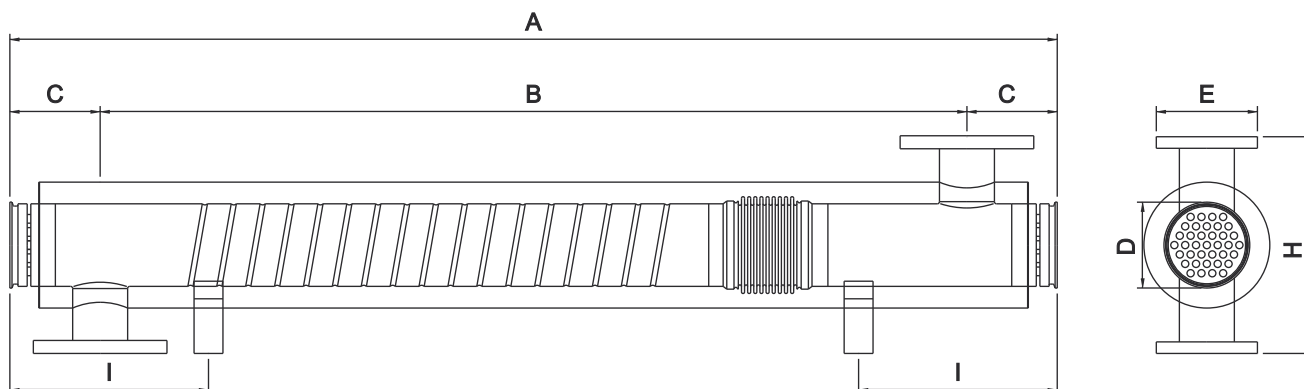

MODEL	DIMENSIONS [mm]						
	A	B	C	D	E	H	I
MLP 114 37 12 1 1000	950	700	125	CLAMP 4"	EN 1092-1 DN 65 PN.16	300	275
MLP 114 37 12 1 1500	1450	1200					
MLP 114 37 12 1 2000	1950	1700					
MLP 114 37 12 1 3000	2950	2700					
MLP 114 37 12 1 6000	5950	5700					

Not binding technical datas; may be modified by the Manufactures without advise

MODEL	SHELL VOLUME [litres]	TUBES VOLUME [litres]	EXCHANGE AREA [m ²]	SHELL SECTION [mm ²]	TUBES SECTION [mm ²]	WEIGHT [kg]
MLP 139 27 18 1 1000	7.16	4.47	1.26	7592.04	5428.67	27.2
MLP 139 27 18 1 1500	10.96	7.19	2.02	7592.04	5428.67	36.3
MLP 139 27 18 1 2000	14.76	9.90	2.78	7592.04	5428.67	45.3
MLP 139 27 18 1 3000	22.35	15.33	4.31	7592.04	5428.67	63.4
MLP 139 27 18 1 6000	45.12	31.62	8.89	7592.04	5428.67	117.5

Category calculation for second group's fluids - Gas, melted gas and liquids with a steam tension at maximum temperature > 0.5 bar

Article 4.3
 1st Category
 2nd Category
 3rd Category

MODEL	VOLUME [litres]	PRESSURE [bar] *												
		1	2	3	4	5	6	7	8	9	10	11	12	
MLP 139 27 18 1 1000	Shell / Tubes						6.9						11.1	
MLP 139 27 18 1 1500	Shell / Tubes				4.5		6.9							
MLP 139 27 18 1 2000	Shell / Tubes			3.3		5.0								
MLP 139 27 18 1 3000	Shell / Tubes		2.2		3.2				8.9					
MLP 139 27 18 1 6000	Shell / Tubes	1.1	1.5			4.4		6.3						

* for higher pressure contact MBS

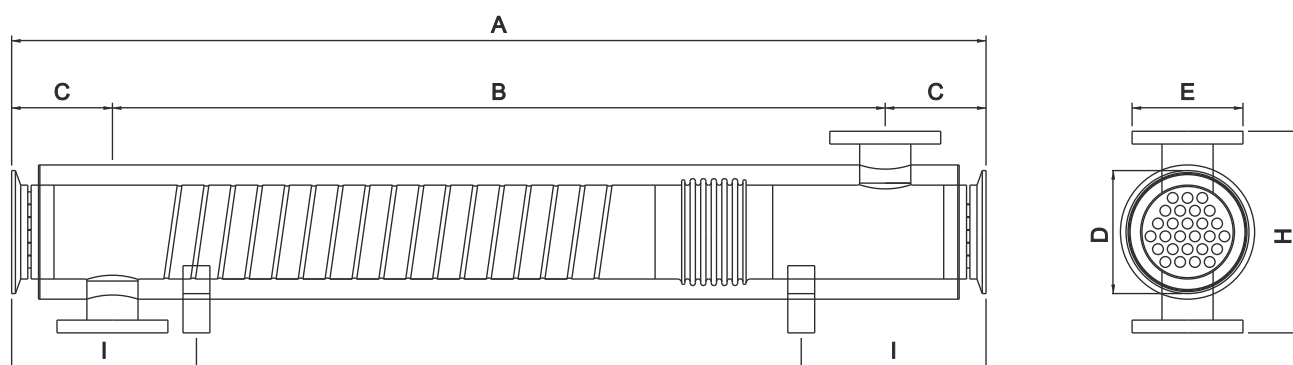

MODEL	DIMENSIONS [mm]						
	A	B	C	D	E	H	I
MLP 139 27 18 1 1000	950	650	150	DIN 32676 DN 150 ASME BPE CLAMP 6"	EN 1092-1 DN 80 PN.16 more connections on demand	340	325
MLP 139 27 18 1 1500	1450	1150					
MLP 139 27 18 1 2000	1950	1650					
MLP 139 27 18 1 3000	2950	2650					
MLP 139 27 18 1 6000	5950	5650					

Not binding technical datas; may be modified by the Manufactures without advise

MODEL	SHELL VOLUME [litres]	TUBES VOLUME [litres]	EXCHANGE AREA [m ²]	SHELL SECTION [mm ²]	TUBES SECTION [mm ²]	WEIGHT [kg]
MLP 139 52 12 1 1000	7.98	3.37	1.62	8581.65	4084.07	29.8
MLP 139 52 12 1 1500	12.27	5.41	2.60	8581.65	4084.07	40.2
MLP 139 52 12 1 2000	16.56	7.45	3.58	8581.65	4084.07	50.6
MLP 139 52 12 1 3000	25.14	11.53	5.54	8581.65	4084.07	71.5
MLP 139 52 12 1 6000	50.89	23.79	11.42	8581.65	4084.07	134

Category calculation for second group's fluids - Gas, melted gas and liquids with a steam tension at maximum temperature > 0.5 bar

Article 4.3
 1st Category
 2nd Category
 3rd Category

MODEL	VOLUME [litres]	PRESSURE [bar] *											
		1	2	3	4	5	6	7	8	9	10	11	12
MLP 139 52 12 1 1000	Shell / Tubes						6.2						
MLP 139 52 12 1 1500	Shell / Tubes				4.0					9.2			
MLP 139 52 12 1 2000	Shell / Tubes			3.0			6.7						12.0
MLP 139 52 12 1 3000	Shell / Tubes	1.9				4.3		7.9					
MLP 139 52 12 1 6000	Shell / Tubes		2.1	3.9			6.3		8.4				

* for higher pressure contact MBS

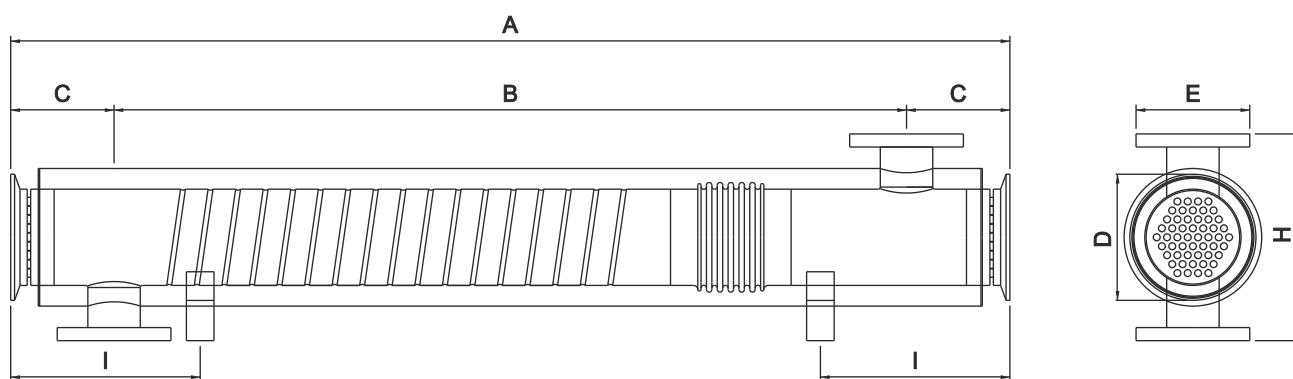

MODEL	DIMENSIONS [mm]						
	A	B	C	D	E	H	I
MLP 139 52 12 1 1000	950	650	150	DIN 32676 DN 150 ASME BPE CLAMP 6"	EN 1092-1 DN 80 PN.16	340	325
MLP 139 52 12 1 1500	1450	1150					
MLP 139 52 12 1 2000	1950	1650					
MLP 139 52 12 1 3000	2950	2650					
MLP 139 52 12 1 6000	5950	5650					

Not binding technical datas; may be modified by the Manufactures without advise

MODEL	SHELL VOLUME [litres]	TUBES VOLUME [litres]	EXCHANGE AREA [m ²]	SHELL SECTION [mm ²]	TUBES SECTION [mm ²]	WEIGHT [kg]
MLP 168 37 18 1 1000	11.72	6.13	1.72	11786.07	7439.29	37.2
MLP 168 37 18 1 1500	17.62	9.85	2.77	11786.07	7439.29	49.0
MLP 168 37 18 1 2000	23.51	13.57	3.82	11786.07	7439.29	60.8
MLP 168 37 18 1 3000	35.30	21.01	5.91	11786.07	7439.29	84.5
MLP 168 37 18 1 6000	70.65	43.33	12.19	11786.07	7439.29	155.3

Category calculation for second group's fluids - Gas, melted gas and liquids with a steam tension at maximum temperature > 0.5 bar

Article 4.3
 1st Category
 2nd Category
 3rd Category

MODEL	VOLUME [litres]	PRESSURE [bar] *												
		1	2	3	4	5	6	7	8	9	10	11	12	
MLP 168 37 18 1 1000	Shell / Tubes				4.2					8.1				
MLP 168 37 18 1 1500	Shell / Tubes		2.8				5.0						11.3	
MLP 168 37 18 1 2000	Shell / Tubes		2.1		3.6					8.5				
MLP 168 37 18 1 3000	Shell / Tubes	1.4		2.3			5.6					9.5		
MLP 168 37 18 1 6000	Shell / Tubes		1.1	2.8			4.6							

* for higher pressure contact MBS

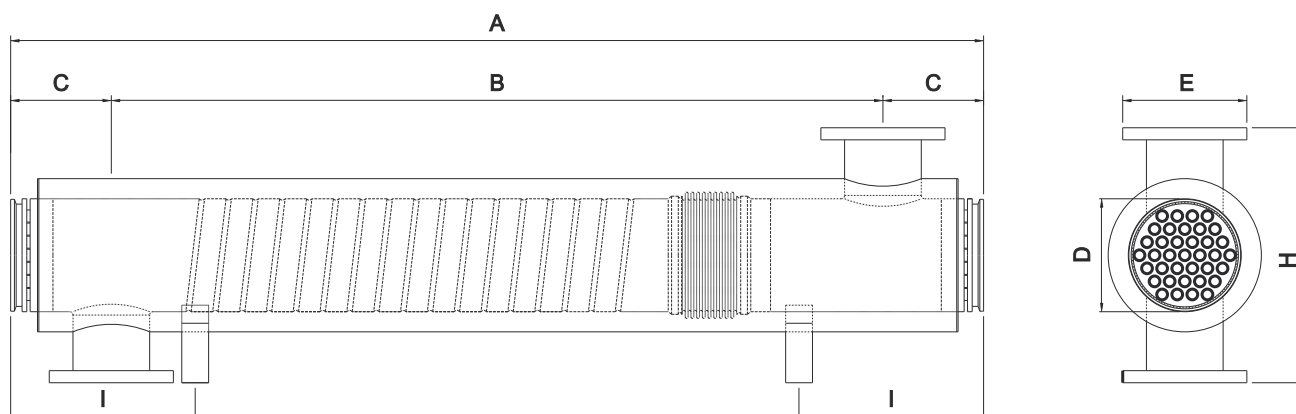

MODEL	DIMENSIONS [mm]						
	A	B	C	D	E	H	I
MLP 168 37 18 1 1000	950	650	150	DIN 32676 DN 150 ASME BPE CLAMP 6"	EN 1092-1 DN 80 PN.16	380	325
MLP 168 37 18 1 1500	1450	1150					
MLP 168 37 18 1 2000	1950	1650					
MLP 168 37 18 1 3000	2950	2650					
MLP 168 37 12 1 6000	5950	5650					

Not binding technical datas; may be modified by the Manufactures without advise

MODEL	SHELL VOLUME [litres]	TUBES VOLUME [litres]	EXCHANGE AREA [m ²]	SHELL SECTION [mm ²]	TUBES SECTION [mm ²]	WEIGHT [kg]
MLP 168 88 12 1 1000	11.28	5.70	2.73	11248.86	6911.50	44.8
MLP 168 88 12 1 1500	16.91	9.15	4.39	11248.86	6911.50	60.8
MLP 168 88 12 1 2000	22.53	12.61	6.05	11248.86	6911.50	76.8
MLP 168 88 12 1 3000	33.78	19.52	9.37	11248.86	6911.50	108.8
MLP 168 88 12 1 6000	67.53	40.25	19.32	11248.86	6911.50	204.7

Category calculation for second group's fluids - Gas, melted gas and liquids with a steam tension at maximum temperature > 0.5 bar

Article 4.3
 1st Category
 2nd Category
 3rd Category

MODEL	VOLUME [litres]	PRESSURE [bar] *												
		1	2	3	4	5	6	7	8	9	10	11	12	
MLP 168 88 12 1 1000	Shell / Tubes				4.4					8.7				
MLP 168 88 12 1 1500	Shell / Tubes		2.9			5.4						11.8		
MLP 168 88 12 1 2000	Shell / Tubes		2.2	3.9					8.8					
MLP 168 88 12 1 3000	Shell / Tubes	1.4	2.5		5.9						10.2			
MLP 168 88 12 1 6000	Shell / Tubes	1.2	2.9		4.9									

* for higher pressure contact MBS

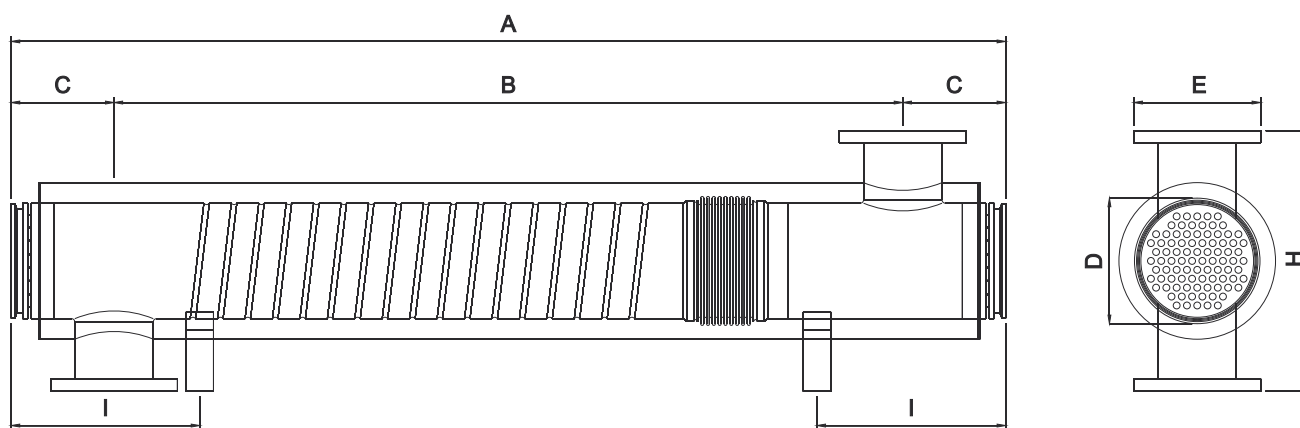

MODEL	DIMENSIONS [mm]						
	A	B	C	D	E	H	I
MLP 168 88 12 1 1000	950	650	150	DIN 32676 DN 150 DIN 11864-2 DN 150 more connections on demand	EN 1092-1 DN 80 PN.16 more connections on demand	380	325
MLP 168 88 12 1 1500	1450	1150					
MLP 168 88 12 1 2000	1950	1650					
MLP 168 88 12 1 3000	2950	2650					
MLP 168 88 12 1 6000	5950	5650					

Not binding technical datas; may be modified by the Manufactures without advise

Sanitary pharmaflo multitube serie

Model MLP 219 61 18

MODEL	SHELL VOLUME [litres]	TUBES VOLUME [litres]	EXCHANGE AREA [m ²]	SHELL SECTION [mm ²]	TUBES SECTION [mm ²]	WEIGHT [kg]
MLP 219 61 18 1 1000	18.68	10.11	2.84	20816.20	12264.78	59.5
MLP 219 61 18 1 1500	29.09	16.24	4.57	20816.20	12264.78	77.6
MLP 219 61 18 1 2000	39.50	22.37	6.29	20816.20	12264.78	95.6
MLP 219 61 18 1 3000	60.31	34.64	9.74	20816.20	12264.78	131.8
MLP 219 61 18 1 6000	122.76	71.43	20.09	20816.20	12264.78	240.2

Category calculation for second group's fluids - Gas, melted gas and liquids with a steam tension at maximum temperature > 0.5 bar

Article 4.3
 1st Category
 2nd Category
 3rd Category

MODEL	VOLUME [litres]	PRESSURE [bar] *												
		1	2	3	4	5	6	7	8	9	10	11	12	
MLP 219 61 18 1 1000	Shell / Tubes		2.6			4.9						10.7		
MLP 219 61 18 1 1500	Shell / Tubes	1.7		3.0			6.8							12.3
MLP 219 61 18 1 2000	Shell / Tubes	1.2	2.2			5.0				8.9				
MLP 219 61 18 1 3000	Shell / Tubes		1.4	3.3			5.7							
MLP 219 61 18 1 6000	Shell / Tubes	1.6	2.7							8.1				

* for higher pressure contact MBS

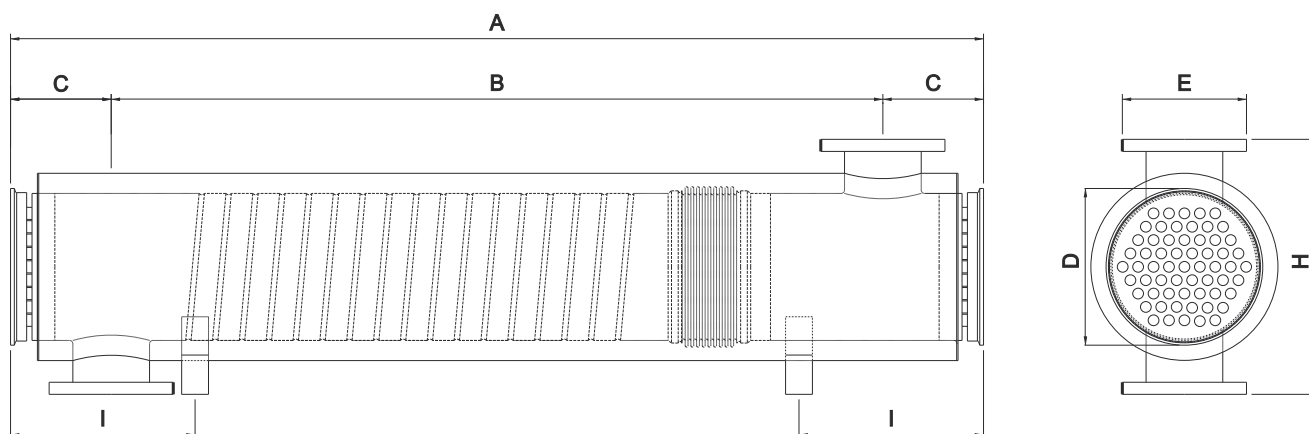

MODEL	DIMENSIONS [mm]						
	A	B	C	D	E	H	I
MLP 219 61 18 1 1000	950	600	175	CLAMP ISO 2852 DN 200 FLANGE TO DRAW more connections on demand	EN 1092-1 DN 100 PN.16 more connections on demand	400	325
MLP 219 61 18 1 1500	1450	1100					
MLP 219 61 18 1 2000	1950	1600					
MLP 219 61 18 1 3000	2950	2600					
MLP 219 61 18 1 6000	5950	5600					

Not binding technical datas; may be modified by the Manufacturers without advise

MODEL	SHELL VOLUME [litres]	TUBES VOLUME [litres]	EXCHANGE AREA [m ²]	SHELL SECTION [mm ²]	TUBES SECTION [mm ²]	WEIGHT [kg]
MLP 219 143 12 1 1000	17.88	9.25	4.44	19828.80	11231.19	71.2
MLP 219 143 12 1 1500	27.79	14.87	7.14	19828.80	11231.19	95.9
MLP 219 143 12 1 2000	37.71	20.49	9.83	19828.80	11231.19	120.5
MLP 219 143 12 1 3000	57.54	31.72	15.22	19828.80	11231.19	169.9
MLP 219 143 12 1 6000	117.02	65.41	31.40	19828.80	11231.19	317.8

Category calculation for second group's fluids - Gas, melted gas and liquids with a steam tension at maximum temperature > 0.5 bar

Article 4.3 1st Category 2nd Category 3rd Category

MODEL	VOLUME [litres]	PRESSURE [bar] *												
		1	2	3	4	5	6	7	8	9	10	11	12	
MLP 219 143 12 1 1000	Shell / Tubes		2.7				5.4						11.1	
MLP 219 143 12 1 1500	Shell / Tubes	1.7		3.3				7.1						
MLP 219 143 12 1 2000	Shell / Tubes	1.3	2.4			5.3				9.7				
MLP 219 143 12 1 3000	Shell / Tubes		1.5	3.4				6.3						
MLP 219 143 12 1 6000	Shell / Tubes	1.7		3.0					8.5					

* for higher pressure contact MBS

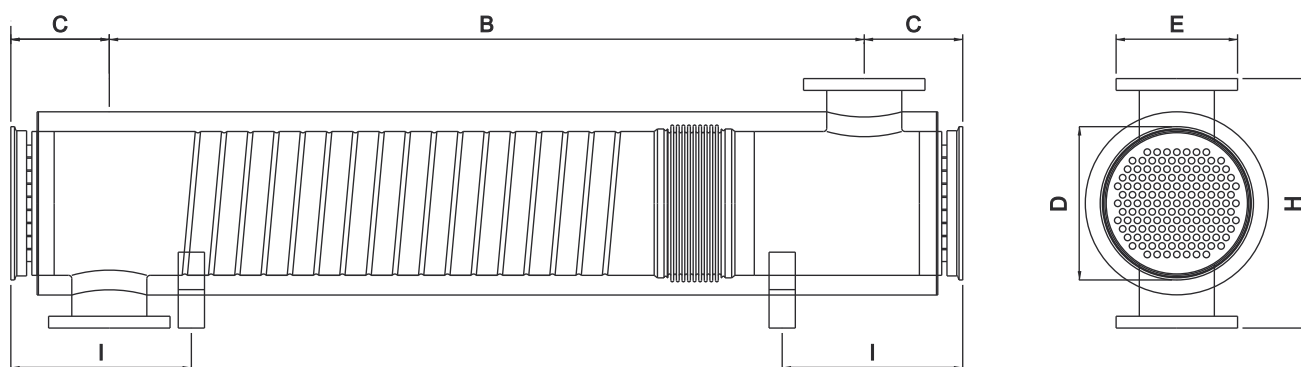

MODEL	DIMENSIONS [mm]						
	A	B	C	D	E	H	I
MLP 219 143 12 1 1000	950	600	175	CLAMP ISO 2852 DN 200 FLANGE TO DRAW more connections on demand	EN 1092-1 DN 100 PN.16 more connections on demand	400	325
MLP 219 143 12 1 1500	1450	1100					
MLP 219 143 12 1 2000	1950	1600					
MLP 219 143 12 1 3000	2950	2600					
MLP 219 143 12 1 6000	5950	5600					

Not binding technical datas; may be modified by the Manufactures without advise

Sanitary pharmaflo multitube serie

Codification

MLP	76	7	18	1	3000	C	C	S	A	B
									Material Product / Service A - EN 1.4301 - AISI 304 B - EN 1.4435 - AISI 316 L EN 1.4404 - AISI 316 L	
									Gaskets Material S - SILICONE V - VITON N - NBR E - EPDM T - TEFLON - GASKET'S NOT INCLUDED	
									Element connections Product / Service C - ASME BPE - ISO 2852 - DIN 11864 - 2 - 3 - DIN 32676 F - FLANGE EN - ANSI	
									Lenght [mm]	
									Expansion joint 0 - Excluded 1 - Included	
									Product diameter [mm]	
									Inner tubes number	
									Sheet diameter [mm]	
Monotube version MLP - Fixed double tubesheet version										